

# HOME

SERIES

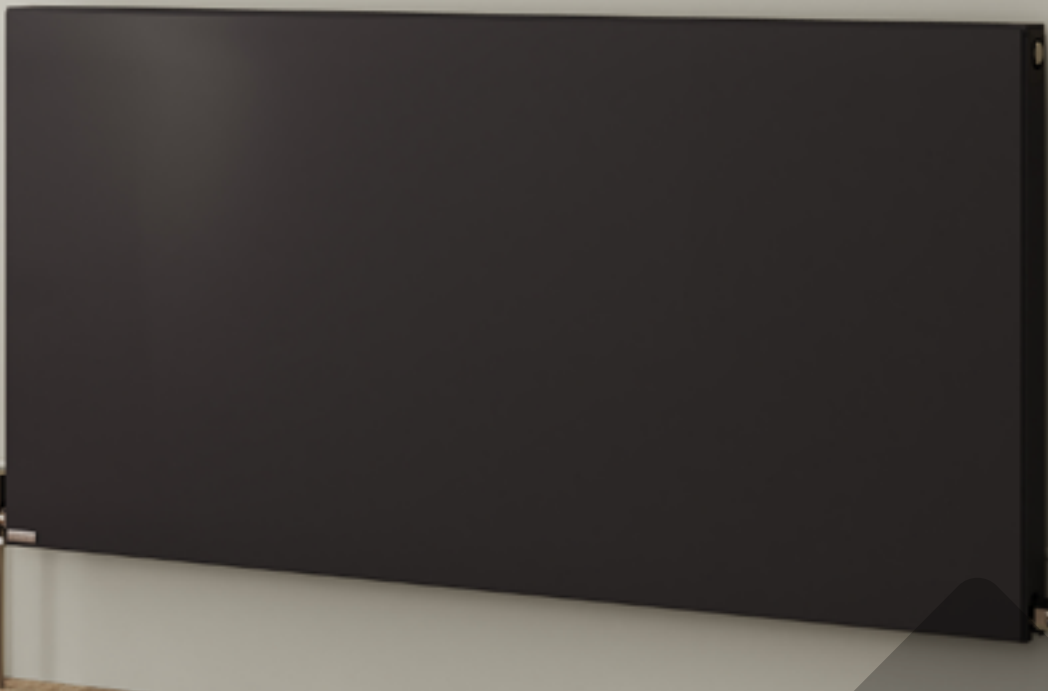

*Compact Flat  
Concept*

## 50 $\Delta$ t

(75/65/20°C)

Height mm	Length mm	Stelrad UIN	Heat output		Stelrad UIN	Heat output	
			Watts	Btu/h		Watts	Btu/h
<b>600</b>	400	21601104h	364	1242	21602204h	654	2231
	600	21601106h	547	1866	21602206h	980	3344
	800	21601108h	729	2487	21602208h	1307	4459
	1000	21601110h	911	3108	21602210h	1634	5575
	1200	21601112h	1093	3729	21602212h	1961	6691
	1400	21601114h	1275	4350	21602214h	2288	7807

$\Delta$ t50 is the UK's industry standard for heating outputs, which has an operating temperature of 75/65/20°C. If you have a low temperature heat source you may wish to consider  $\Delta$ t40 or  $\Delta$ t30 output (see your installer or system designer or download from [www.stelrad.com](http://www.stelrad.com)).

For EN442 data, technical and installation information please visit our website: [www.stelrad.com](http://www.stelrad.com) and search product downloads.

# COMPACT FLAT CONCEPT



## WALL MOUNTING AND LUG INFORMATION

All dimensions in mm. Inches in brackets.

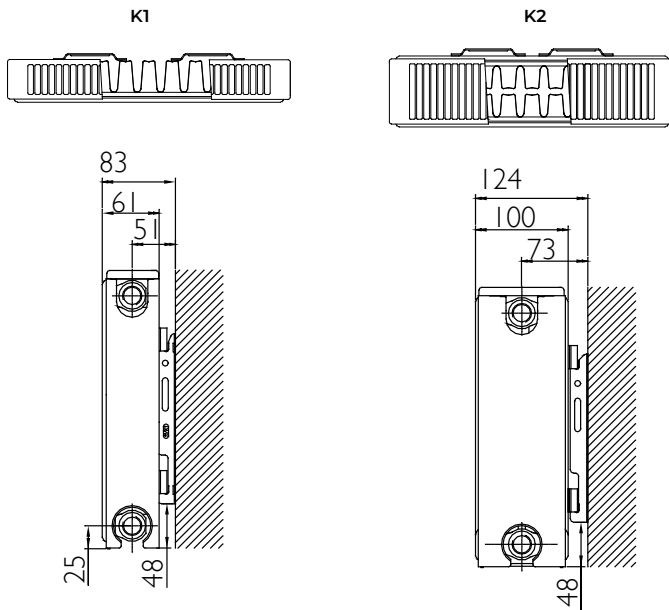

## MOUNTING BRACKETS

All dimensions in mm. Inches in brackets. Floor mounting brackets available.

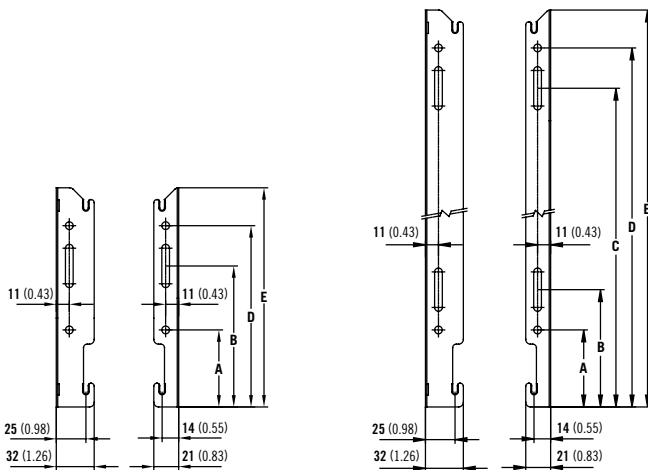

Dimensions	mm	inches
Height	600	23.62
A	65	2.56
B	99	3.90
C	419	16.50
D	453	17.83
E	485	19.09

# COMPACT FLAT CONCEPT



## K1 & K2 LUG POSITIONS (New as of June 2016).

All dimensions in mm. Inches in brackets.

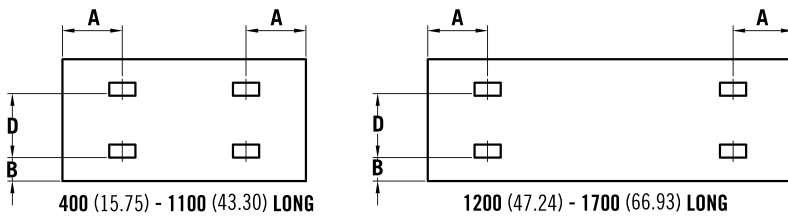

### PANEL HEIGHT

D		D	
mm	in	mm	in
600	23.62	455	17.91

### K1

### K2

Dimensions	mm	in	mm	in
A 400mm	117	4.61	133	5.24
A 500 - 2000mm	150	5.91	133	5.24
B 400 - 2000mm	60	2.36	60	2.36

### K1

### K2

Dimensions	mm	in	mm	in
A 400mm	117	4.61	133	5.24
A 500 - 2000mm	150	5.91	133	5.24
B 400 - 2000mm	60	2.36	60	2.36

## CONNECTIONS

Each radiator comes with ½" inlet connections as standard.

## PIPING OPTIONS

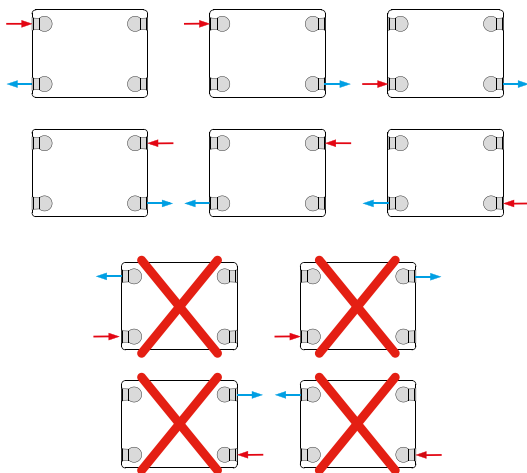

## EN 442 CERTIFICATION DATA - CETIAT TESTED IN ACCORDANCE WITH BS EN 442

Type	K1	K2
Height	600	600
W/m at 75/65/20	911	1634
n-coefficients	1.28	1.32
Heated surface area (m <sup>2</sup> /m)	4.66	7.74
Weight (kg/m)	24.65	40.00
Water contents (l/m)	3.25	6.60
Wall to tap centre (mm)	51	73

### PRESSURE DROPS

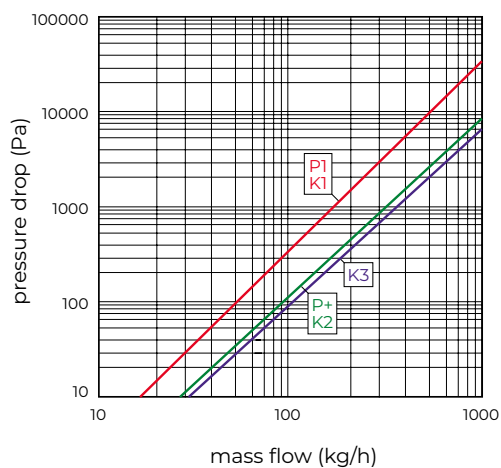

Type	Kv
P1 / K1	1.67
P+ / K2	3.32
K3	3.65